

Up Blast Extracting Fan

60 Hertz

Commercial Kitchens Food Trucks



Low Profile Direct Drive
Up Blast Roof Mounted

airSupply[™]

US AirSupply Corp.,
HOUSTON, TEXAS, U. S. A.
www.AirSupplycorp.com

PRODUCT SPECIFICATIONS

- **Description/Application**
- Low Profile Centrifugal Up Blast Extractors are designed not just for restaurants but also for Food Truck Industry.
- The Extractors are specially designed to handle Deep Oil Frying Equipment, and to discharge grease, excessive heat and smoke vertically in the air.
- Backward Curved Impeller and High Capacity Motor can allow the fan to operate on a Very High Static Pressure while able to maintain the High Air flow
- **Construction**
- Light Aluminum 1060 Body construction and Blower made up of Aluminum 3003 H14.
- GI 18 Gauge Base to withhold the air pressure on the Nuts in Roof Curb, while Food Truck is on the Move.

- Impeller is made of Heavy Gauge Aluminum Blade to resist the High Static Pressure.
- Waterproof Electrical Connection in the Lower Part of the Fan for easy Connections.
- UL listed Electrical components
- Air Tight Oil & Water Drain

Standard Equipment/Features

- Die Cast Heavy 4" Duty Hub
- Keyed 5/8" Motor Shaft, with Set Screw
- All serviceable parts are accessible from one Side of the unit
- Quite Impeller Fan
- Dynamically Balanced Impeller
- Permanent RUN Capacitor Motor
- Option with one of the world Best American made Motor

Performance Data Items	Model		
	E-DEC1010-1	E-DEC1212-1	E-DEC1512-1
Rating			
Nominal Air Flow Rate (cfm)	2,050	2550	3985
Motor Capacity (Hp)	1/2	3/4	1-1/2
Noise Level (Sones)	14.2	15.5	16.1
Electrical Data			
Power Supply (v / ph / hz)	115/ 1 / 60		
Power Input (kw)	0.82	0.82	1.14
Full Load Current (amps)	8.9	9.6	13.4
Blower			
Type	Centrifugal Backward Curve Single Inlet		
No of Blades	8	8	10
Size DxL (in)	13 x 5 1/4	14 x 5 1/4	16 x 5.5
Inlet Size (in)	10	12	15

Dimensional Data (Inches)

Model	Height	Diameter	Curb cap	Weight
E-DUC1010-1	B 22"	A 24"	D 21"	55 Lbs.
	C 19"			
E-DUC1212-1	B 22"	A 26"	D 25"	61 Lbs.
	C 19"			
E-DUC1512-1	B 22"	A 26"	D 25"	74 Lbs.
	C 19"			

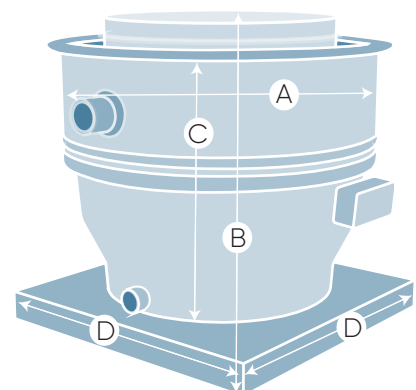

NOTE: SPECIFICATION AND PERFORMANCE DATA LISTED HERE IN ARE SUBJECT TO CHANGE WITHOUT NOTICE.